



ALBEDO Net.Shark is an FPGA-based tap that improves Wireshark performance by means of hardware programmable filters. It can capture packets at wire-speed (2 x GbE) something that Wireshark CPUs can't do.

Datasheet

# ALBEDO Net.Shark



**Wireshark** is a network packet analyzer to examine communication network.

Important features are: live packet data capture, display packets with very detailed protocol information, open/save data, import/export from/to other programs. It can search/filter data on many criteria.

Wireshark is open source and probably the best packet analyzer available.

**Net.Shark** is a FPGA based tap with filtering capabilities, that connected in pass-through mode, is able to capture traffic at wire-speed. Packets are transmitted through two ports and traffic compliant with one of the filters is sent to Wireshark.

## 1. CONFIGURATION

- Autonegotiation parameters including bit rate (10, 100, and 1000 Mbit/s) and duplex mode
- Configurable MTU size

### 1.1 Ports and Interfaces

- Drop Ports: Dual RJ-45 port for electrical connection 10/100/1000BASE-T
- Pass-thought Ports: SFPs based p to 1 Gb/s
- SFP interfaces including: 10BASE-T, 100BASE-TX, 100BASE-FX, 1000BASE-T, 1000BASE-SX, 1000BASE-LX

### 1.2 Formats and Protocols

- Ethernet frame: IEEE 802.3, IEEE 802.1Q
- IP packet: IPv4 (IETF RFC 791)
- Jumbo frames: up to 17 kB MTU (Maximum Transmission Unit)
- Throughput between measurement ports: 1 Gb/s or 1,500,000 frames/s in each direction

## 2. OPERATION

- GbE SFP interfaces are used to connect -in pass thought mode- to the network Host A and Host B.

- GbE RJ45 interfaces drop the filtered frames to the WireShark device.
- All frames coming to Net.Shark are forwarded to destination without delay or lost.
- Frames compliant with filtering conditions and copied to Wireshark device.
- Operation is based on 16 filters per SFP port.
- Filtered frames can be aggregated in one drop port.

## 3. ETHERNET PHY AND MAC BLOCKS

- Ethernet frame formats: IEEE 802.3, IEEE 802.1Q.
- Jumbo frames with MTU up to 10 kB.
- Throughput 2xGbE (up to 2 x1.500.000 frames/s).
- Pass-thru Ports support 10BASE-T, 100BASE-TX, 100BASE-FX 1000BASE-T, 1000BASE-SX and 1000BASE-LX.
- Drop Ports support: 10BASE-T, 100BASE-TX, 1000BASE-T.

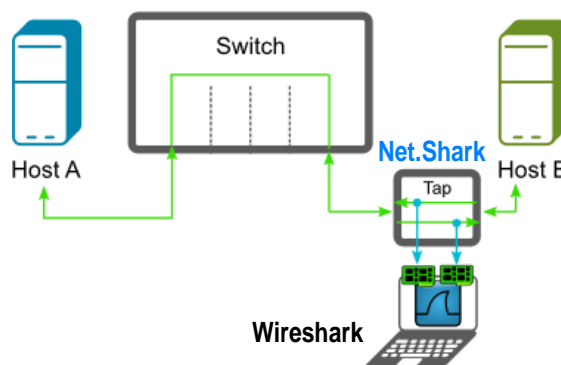

Figure 1. Net.Shark and Wireshark in operation.

CONFIDENTIAL

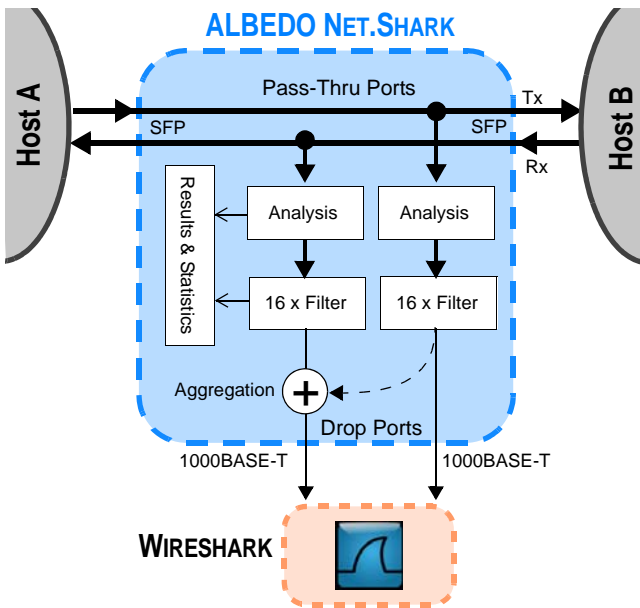

Figure 2. Logical block diagram.

#### 4. FILTERS

- 16 simultaneous filters can be applied to the traffic.
- The Filtering process is executed sequentially.
- When a packet satisfies a filter is sent to the Drop Port and immediately forwarded to the output. No more filters are processed.
- Each packet may modify only the statistics of one filter
- Customizable filters defined by field contents on Ethernet, IP, UDP and TCP headers
- Agnostics filters defined by 16 bits masks and user defined offset
- Lawful filter: 64 byte pattern match at any place in the frame payload.



##### 4.1 Ethernet filters

- Ethernet Selection
- By source and destination MAC addresses. Selection of MAC address sets with masks
- By Ethertype value with selection mask.
- By VLAN-VID with selection mask.
- By VLAN-CoS value with selection mask.

##### 4.2 IP filters

- IPv4 address: source, destination, and source-and-destination
- IP address group: subset of addresses filtered by masks
- Protocol encapsulated in the IP packet (TCP, UDP, Telnet, FTP, etc.)
- DSCP field, single value and range
- TCP/UDP port, single value and range

#### 5. RESULTS

- Autonegotiation results including current bit rate, duplex mode, Ethernet interface
- SFP presence, vendor, and part number
- Traffic statistics per each of the Four Ports
- Statistics for both transmit and receive directions
- Frame counts: Ethernet, and IEEE 802.1Q
- Frame counts: unicast, multicast and broadcast
- Basic error analysis: FCS errors, undersized frames, oversized frames, fragments, jabbers, collisions
- Frame size counts: 64, 65-127, 128-255, 256-511, 512-1023, and 1024-1518 bytes
- Four byte counts: Port A (Tx / Rx) and Port B (Tx / Rx)
- All traffic counters follow RFC 2819
- Counters and statistics per filter (up to 16)

#### 6. USER INTERFACE

- Direct configuration and management in graphical mode using the keyboard and display of the instrument
- Remote access for configuration and management in graphical mode from remote IP site through the Ethernet interface of the control panel
- Remote access with command line (CLI) using of either Telnet or SSH offering for configuration, management and task automation
- Remote access via SNMP for configuration, management and integration

#### 7. GENERAL

- *Instant On* (the equipment measures immediately after power on)
- Operation time with batteries: 3.5 hours (minimum, two battery packs)
- Configuration and report storage and export through attached USB port
- TFT color screen (480 x 272 pixels)
- Dimensions: 223 mm x 144 mm x 65 mm
- Weight: 1.1 kg (with rubber boot, one battery pack)

